

CONIC

Technical description

- Electrostatic powder coated aluminium housing
- Aluminium die cast heat sink
- Tempered safety glass
- Fabricated steel grid cage cover
- SMD LED light source
- SDCM ≤ 3 (3-step Mac Adam)
- Electronic control gear
- Catenary fitting excluding cable and wire
- Input Voltage: 220-240V AC
- Ambient temperature: $-20^{\circ}\text{C} \dots +45^{\circ}\text{C}$
- 100.000 hours product life span (LM80 and TM21)
- 5-year warranty



TECHNICAL DATA

Code	W	Luminous Flux (lm)	Efficiency (lm/W)	CRI	Color Temperature	Dimensions $\text{\O} \times \text{H}$ (mm)
550CON.32.03	32W	2150 lm	$>67 \text{ lm/W}$	>80	4000K	550x510mm

TECHNICAL DRAWING

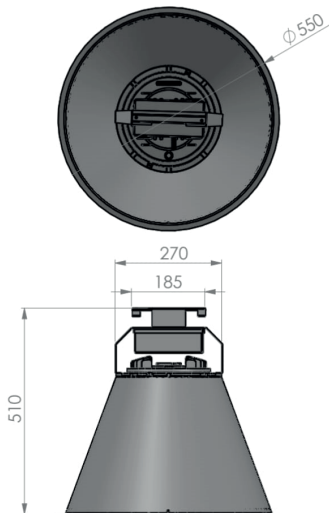

LIGHT BEAM

